

Grit washer - PP

The grit washer (PP) is designed for intensive grit washing and the removal of organic matters in grit. Grit washer is placed at a further stage after the grit separator. By intensive grit washing mostly all residual portion of organic substances are removed.

The hydro-mixture in the grit chamber is first pumped into the grit separator. Here the initial rough separation of grit from the remaining solid phase is carried out. By subsequent washing the grit is rid of almost all the residual portion of organic substances. The connection of the grit washer to the grit separator is carried out by the manufacturer as a part of the delivery, following the order of spatial arrangement specifications for both products.

Specification	
Capacity: Q	up to 0,4 ls ⁻¹ (=1,5 m ³ h ⁻¹) of washed grit
Efficiency of grit separation from organic material: (grit grains > 0,2mm)	97 - 98 %
Consumption of wash water:	1 ls ⁻¹ of wash water at 0,3 MPa, for a period of approx. 15 mins (1 operating cycle)
Diameter of conveyor screw: D	250 mm
Power inputs:	conveyor screw 0,75 kW/ 400 V/ 50 Hz washing 1,1 kW/ 400 V/ 50 Hz electromagnetic valve 34 VA, 230 V
Single cycle period:	period of hydro-mixture pumping + + approx. 15mins wash water
Operating conditions:	a) <i>indoor</i> b) <i>outdoor</i> for temperatures ranging from -20 to +50 °C with heating unit of 1,54 to 2,0 kW/ 220 V/ 50 Hz
<i>Other parameter ranges need to be consulted with the manufacturer</i>	

Product identification: **PP D x Q**

ISO 9001



Tandem of grit washer (PP) and grit separator (SP)



grit washer (PP)

The grit washer is a tank with a special built-in unit, a mixing and scooping mechanism, and a wash water inlet and outlet. By mixing, polluted grit is retained in the rotational layer where grit particles are separated from organic matter. In this process gravitational and rotational forces are employed, and particles of different mass are separated and concentrated in opposite areas. Organic matter and wash water are led to the overflow, and particles of washed grit, after their depositing, are drawn by the conveyor screw towards the outlet. The entire cycle of washing and scooping is controlled from the control switchboard where partial steps can be set.

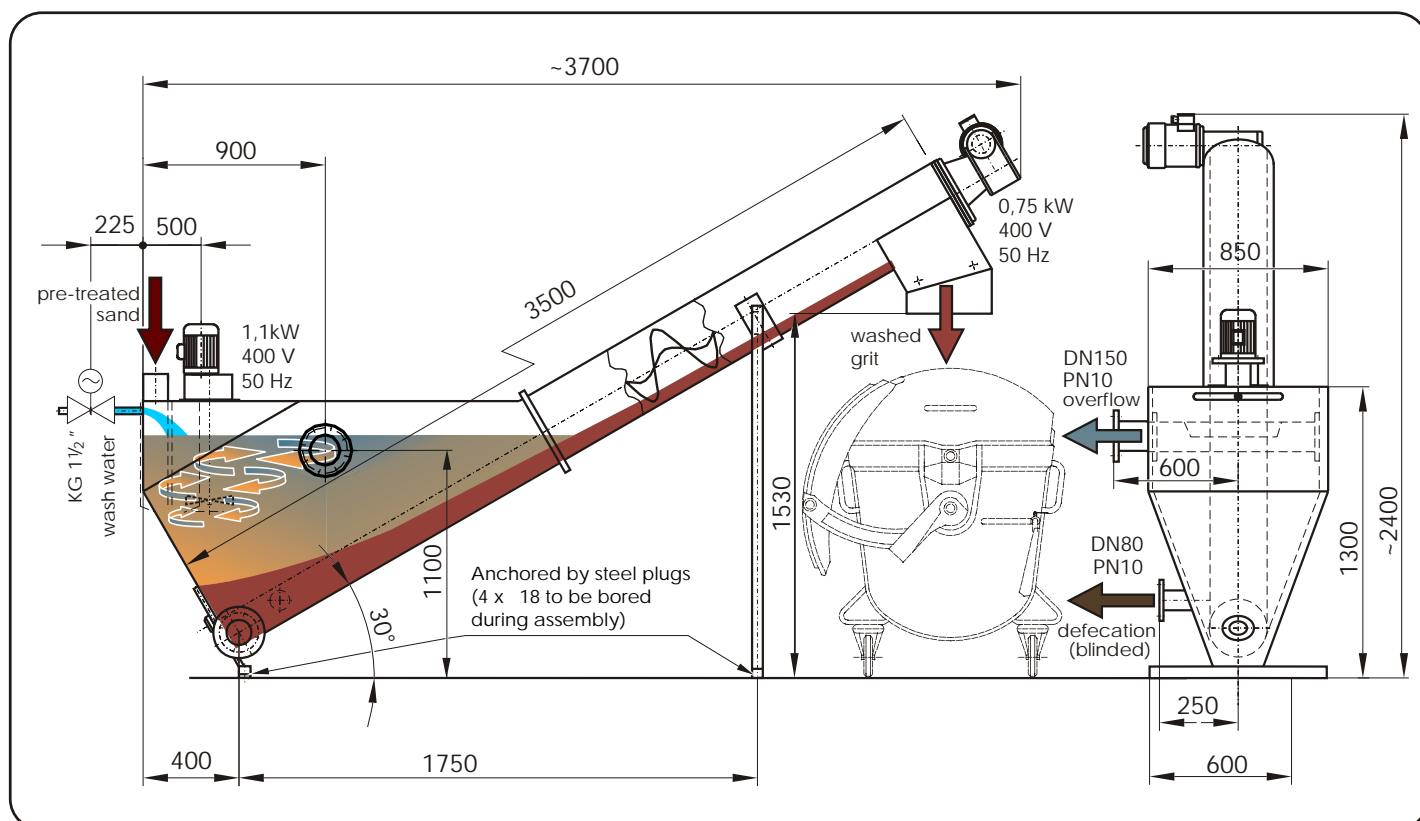

The appropriate incorporation of the PP in the water treatment process is conditioned by the installation of the canal overflow behind the grit chamber so that the separated water with organic substances can be led into the settling tank or biological section of WWTP.

The PP is made of stainless steel, the shaftless screw and gliding rails are made of carbon steel of greater strength. The device is designed for indoor use with optional additional covering with heating unit for outdoor use.

To achieve an optimum incorporation of the equipment in the technological section of waste water treatment plants, *FONTANA R* offers consultations and technical support as a free customer service.



Fontana R, s.r.o. – Příkop 4, 602 00 BRNO, CZECH REPUBLIC
 tel.:00420/ 5/ 45 21 59 32; 5/45 17 58 51; 5/45 17 58 54; tel/fax:00420/ 5/45 21 59 33
<http://www.fontanar.cz>; e-mail: fontanar@fontanar.cz