

Integrated coarse pre-treatment economy IHPE, IHPEL

Integrated coarse pre-treatment ECONOMY (IHPE) is a combination of a skimmed cylinder strainer (SVS) and a grit separator (SP). It ensures an economical and simple solution for trapping of screenings and grit separation from waste water. It can replace the function of self-cleaning screens, grit chambers and grit separators.

This system is designed for low-capacity waste water treatment plants (including industrial applications) with a rate of flow up to 10 l/s (800 m³ per day). The function of ECONOMY pre-treatment system is to trap coarse and solid indissoluble particles - vegetable matter, floating and suspended substances, pebbles, etc. into strainers, and separate grit with grain size exceeding 0.2 mm. During this process, water and most organic substances are drained from the grit.

One of the major advantages of the ECONOMY system is the relatively small built-up area required and the possibility of installing it on a hardened surface without the need to make extensive constructional adjustments.

ISO 9001

Specification	
Rate of flow: Q	5, 7, 10, 15 l/s
Aperture size:	5 mm
Power inputs:	IHPE 0,73 kW/400V IHPEL 1,10 kW/400V
Solenoid valve:	60 VA
Heating IHPE i IHPEL:	2,24 kW/230V
Wash water in intervals:	3 ÷ 5 l/s, 0,3 ÷ 0,6 Mpa
Wash water consumption:	2,5 ÷ 6 m ³ /hod
Operating conditions :	<i>indoor:</i> in a building <i>outdoor:</i> up to -20°C with heating
Material:	stainless steel
<i>Other parameter ranges have to be consulted with the manufacturer.</i>	

Product designation: **IHPE Q** [l.s⁻¹]



The grit separator tank with a conveyor screw is anchored to a foundation and adjusted in order to enable fitting of a skimmed strainer. The strainer is covered and located on the upper lid of the tank. Waste water is pumped onto the SVS, where it is subsequently filtered and runs through to the separator. The trapped solid substance is skimmed by the wiping mechanism and conveyed to the chute and into a container. Grit particles in waste water pass through the strainer into the separator where they are rinsed in intervals with wash water and separated from the organic substances. Discharged water enriched with organic substances is drained to an overflow. The washed grit is conveyed by a conveyor screw into a container. The capacity and types of containers shall be specified during the tender procedures.

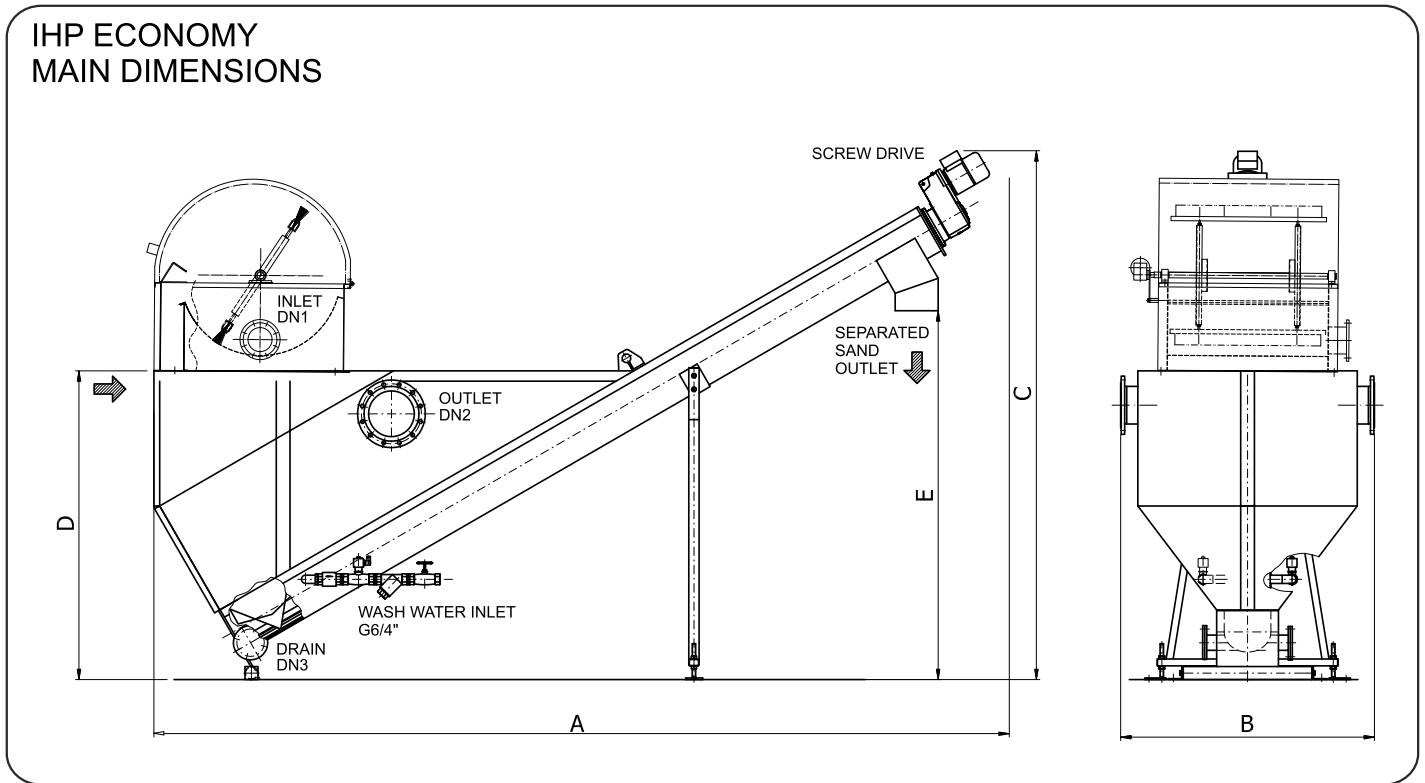

Dimensional series:

Type	Q (l/s)	DN1/PN	DN2/PN	DN3/PN	A	B	C	D	E	kg
IHPE 5	5	100/10	150/10	80/10	4405	980	2730	1600	1800	670
IHPE 7	7	150/10	150/10	80/10	4405	980	2730	1600	1800	690
IHPE 10	10	150/10	200/10	80/10	4420	1200	2730	1600	1800	730
IHPE 15	15	150/10	250/10	80/10	5100	1480	3085	1800	2150	920

Note: The weight specified above applies for non-heated design

The facility drive is provided in the form of an electric gearbox. Both manual control and automatic operation are ensured by control switchboard, which enable adjustment of all time intervals and possibly pump control.

The selection of an adequate device and arrangement, and a proposal for accessories shall be specified within the tender procedures. To achieve an optimum incorporation of the equipment in the technological section of waste water treatment plants, *FONTANA R* offers consultations and technical support as a free customer service.



Fontana R, s.r.o. – Příklad 4, 602 00 Brno, Czech Republic

Tel.: +420 545 175 853; +420 545 175 851; +420 545 175 854; tel/fax: +420 545 175 852
<http://www.fontanar.cz/>; e-mail: fontanar@fontanar.cz